

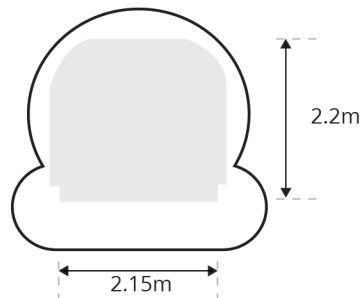

Antonov AN-74

There are many variations of the AN-74 but its primary difference from the AN-72 is that it can be converted in-service from a passenger carrier to a cargo carrier in two hours and can carry 10t of cargo. Like the AN-72, it also has STOL capabilities. It has enhanced avionics from the AN-72 and was designed for use in Arctic weather conditions.

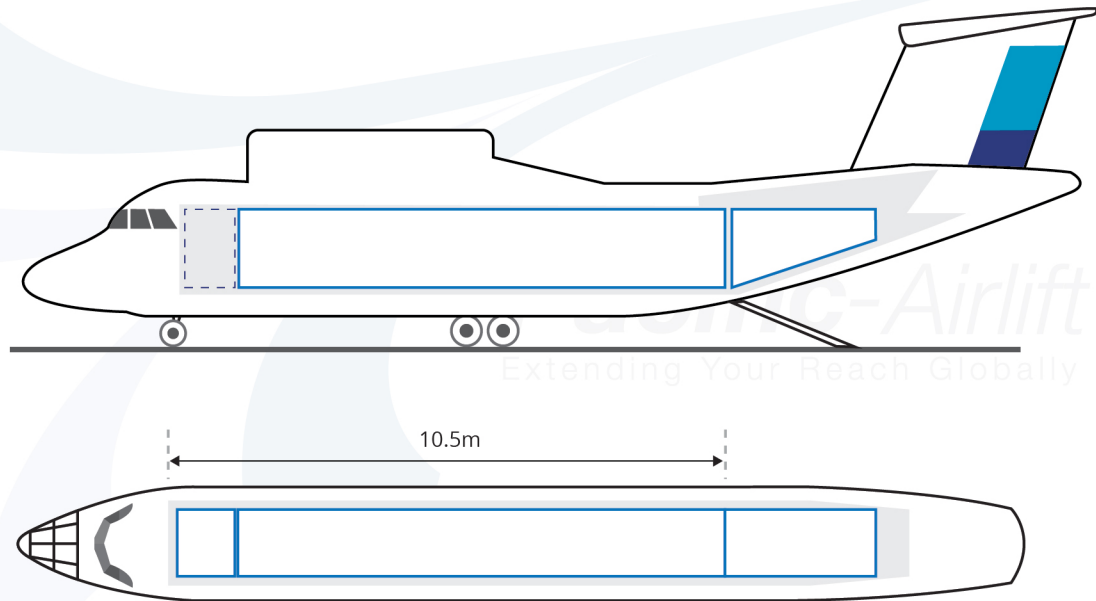

Specifications

Manufacturer	Antonov
Type	AN 74
Cargo Hold Size LxWxH (m)	10.5 x 2.15 x 2.2
Ramp Door Size WxH (m)	2.15 x 2.2
Lower Forward Door WxH (m)	N/A
Lower Aft Door WxH (m)	N/A
Bulk Size WxH (m)	N/A
Payload (kg)	10,000
Volume (m ³)	50
Cruise Speed (kph)	600 (324 knots)
Range Fully Loaded (km)	1,200
Runway Length Requirement (m)	1,000
Runway Length Requirement (ft)	3,281
Powerplant	2 x Turbofan